

EXW-1.8 / EXW-2.7

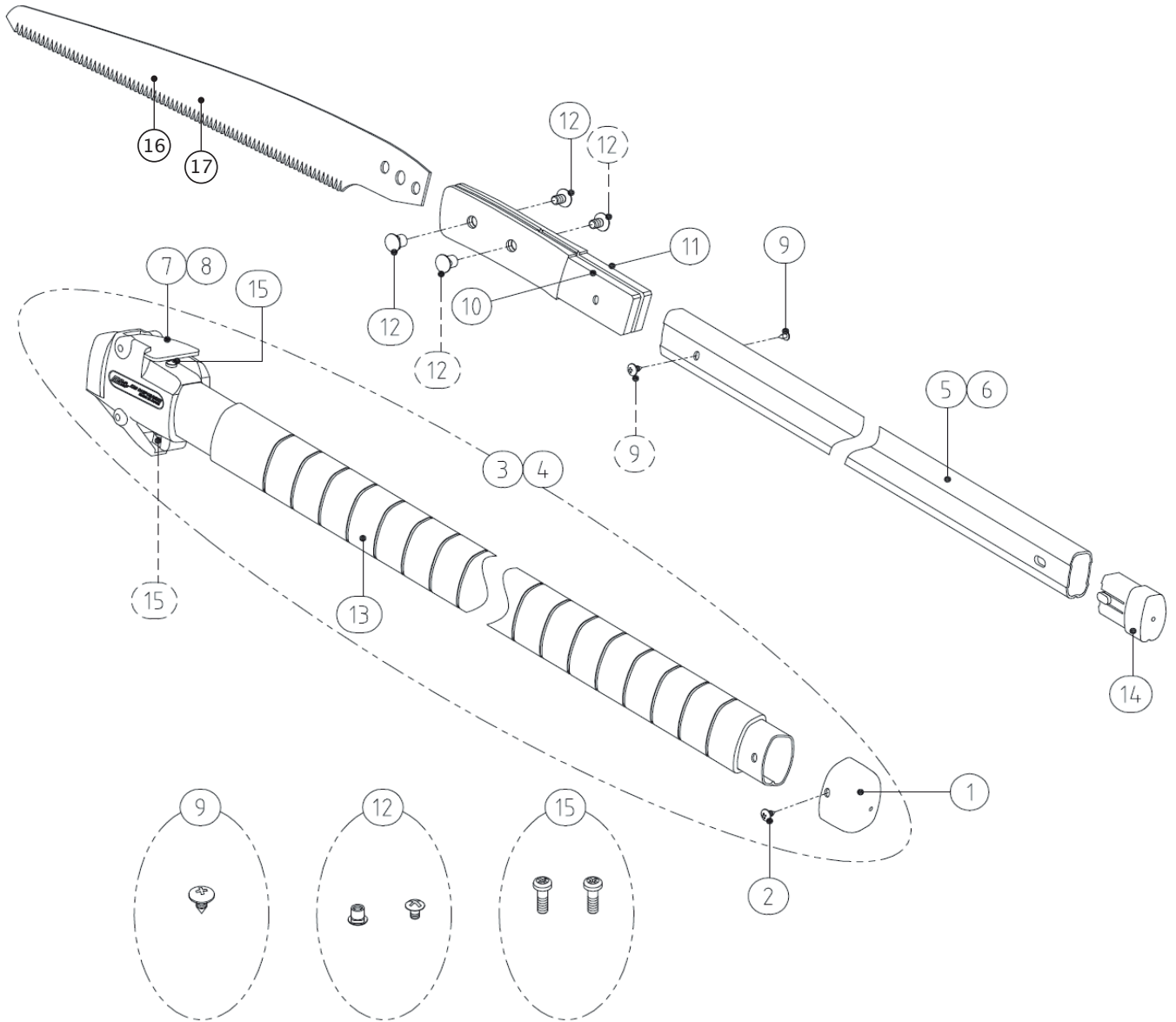

PARTS NO.	SPECIFICATION	PARTS NO.	SPECIFICATION
① SP-300	ENDCAP FOR THE BOTTOM PIPE FOR EXW-1.8/2.7	⑫ SP-308	BLADE HOLDING BOLT & NUT FOR EXW-1.8/2.7 (1PC EACH)
② SP-301	ENDCAP HOLDING SCREW FOR EXW-1.8/2.7 (1PC)	⑬ SP-309	PLASTIC GRIP ONLY FOR THE BOTTOM PIPE FOR EXW-1.8/2.7(1/2 PC.)
③ SP-302	BOTTOM GRIP SET FOR EXW-1.8 (ICL.GRIP AND JOINT CASE)	⑭ SP-310	ENDCAP FOR INNER PIPE FOR EXW-1.8/2.7
④ SP-311	BOTTOM GRIP SET EXW-2.7 (ICL.GRIP AND JOINT CASE)	⑮ SP-333	SCREW OF JOINT CASE FOR EXW-1.8/2.7 (2PCS)
⑤ SP-303	INNER PIPE FOR EXW-1.8 (W/O BLADE HOLDER)	⑯ ARSEXW-1	SPARE BLADE
⑥ SP-312	INNER PIPE FOR EXW-2.7 (W/O BLADE HOLDER)	⑰ ARSEXW-1	SPARE BLADE
⑦ SP-304-A	JOINT CASE FOR EXW-1.8 WITH SCREW		
⑧ SP-304-B	JOINT CASE FOR EXW-2.7 WITH SCREW		
⑨ SP-305	HOLDER FIXING BOLT & NUT FOR EXW-1.8/2.7 (1PC)		
⑩ SP-307	BLADE HOLDER(LEFT) FOR EXW-1.8/2.7		
⑪ SP-306	BLADE HOLDER(RIGHT) FOR EXW-1.8/2.7		